

# RJ Stacey Folding Head Plugging Machine Dimensions- for Class 150# 1.5" – 6"

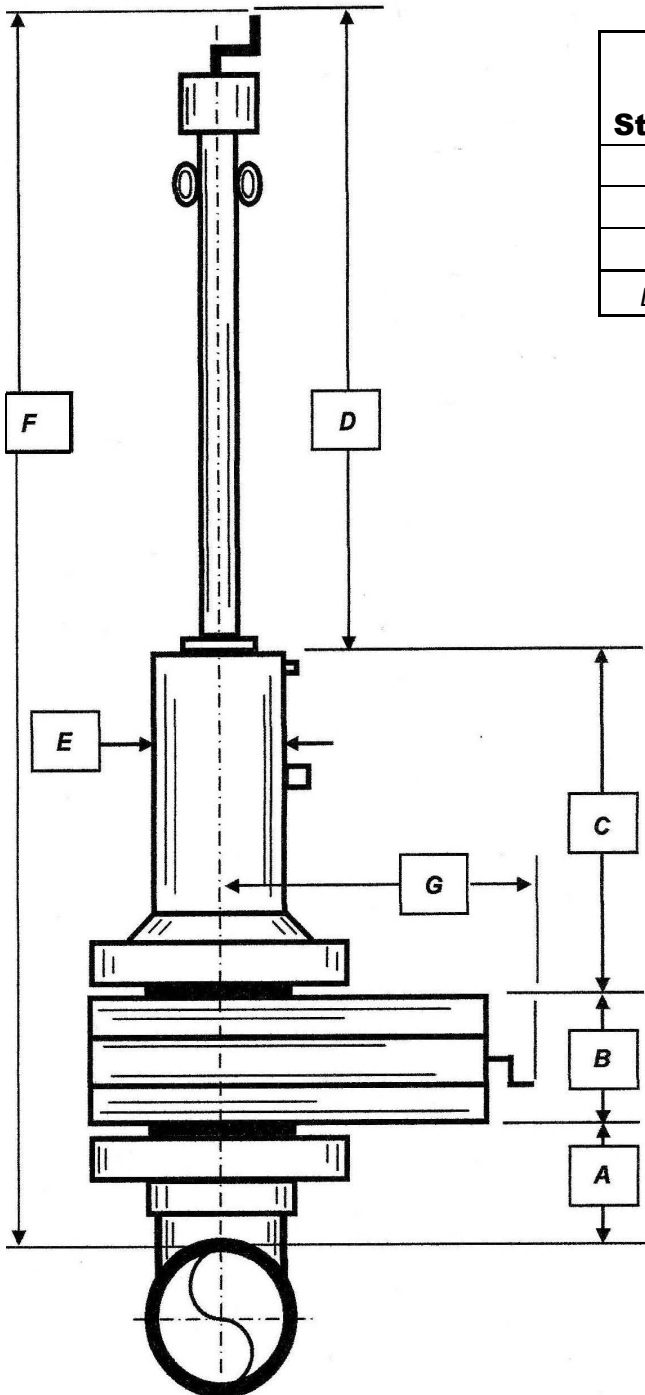

Stopples Size	A	B	C	D	E	F	Total Weight
1.5 and 2"	3.5"	3"	7"	19"	5"	33.5"	26 lbs.
3"	5"	5"	8"	43"	7"	60"	155 lbs.
4" and 6"	6"	6"	11"	43"	9"	66"	260 lbs.

*Dimensions shown are approximate, If you need exact dimensions, please contact us*

**Sandwich Valve**

Size	Weight
2"	15 lbs.
3"	20 lbs.
4"	60 lbs.

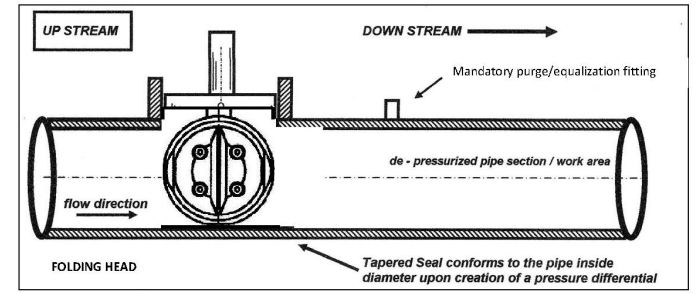
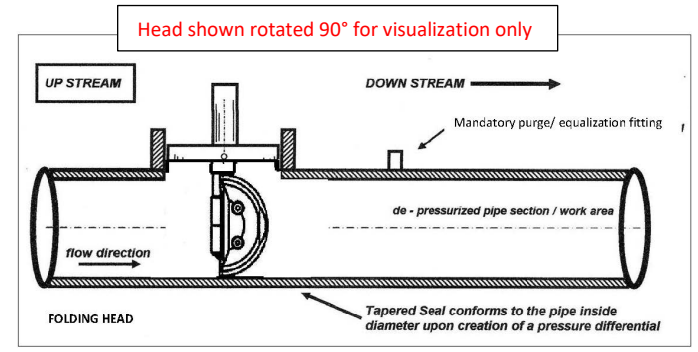

Folding Head Plugging Machine

Tel: 248-330-4707 email: Ryan@rjstacey.com