

# RJ Stacey Folding Head Plugging Machine Dimensions- for Class 150# 14 - 16"

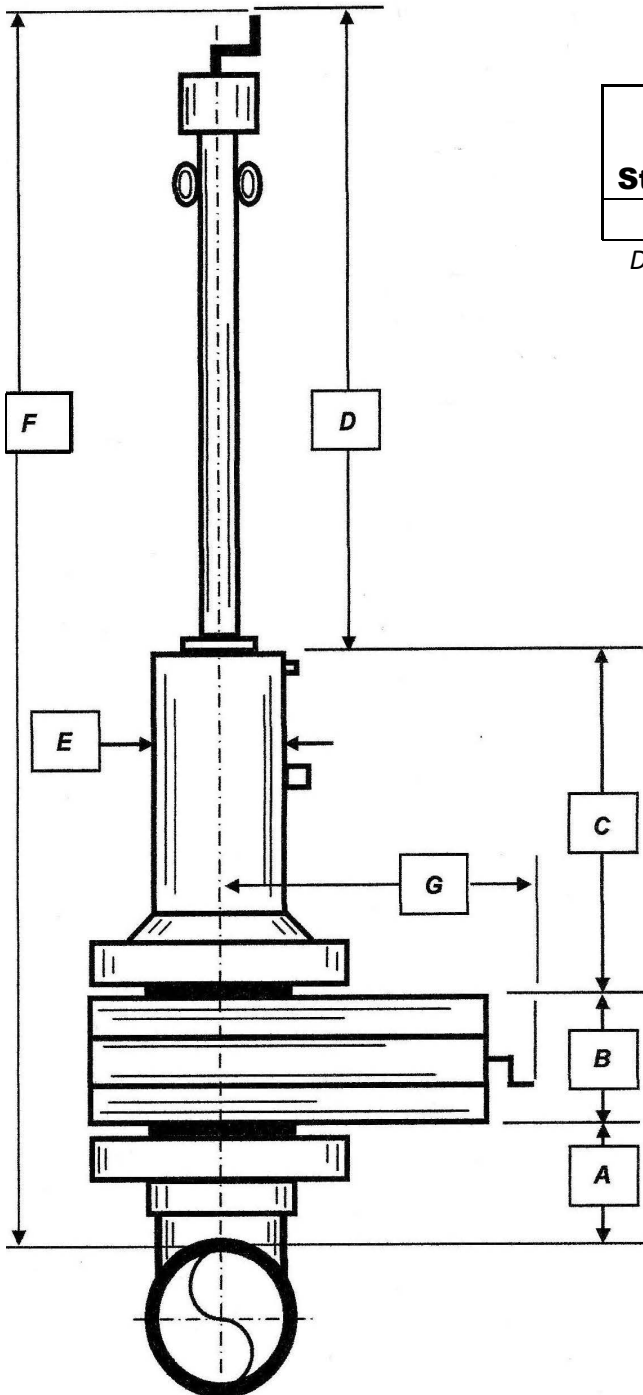

Stopples Size	A	B	C	D	E	F	Total Weight
14" and 16"	8"	13"	36"	60"	12"	117"	800 lbs.

Dimensions shown are approximate, If you need exact dimensions, please contact us

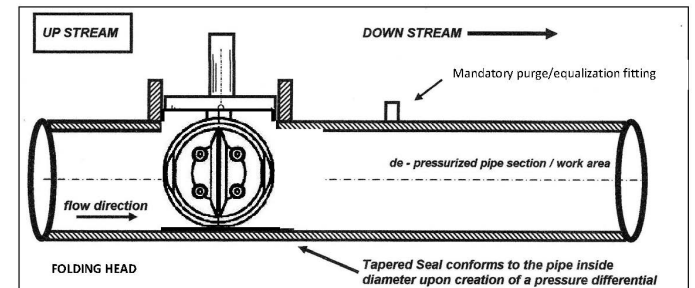
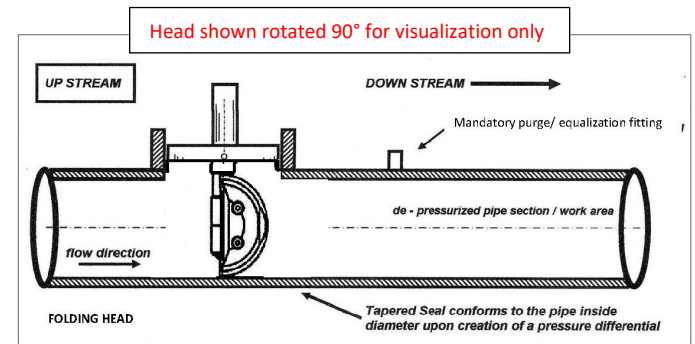

## Sandwich Valve

Size	Weight
10"	220 lbs.

Folding Head Plugging Machine



Tel: 248-330-4707 email: Ryan@rjstacey.com